

# Installation Guide Smart-UPS™ On-Line External Battery Pack SRT192BP/192BP2

## Safety Messages

Read the instructions carefully to become familiar with the equipment before trying to install, operate, service or maintain it. The following special messages may appear throughout this manual or on the equipment to warn of potential hazards or to call attention to information that clarifies or simplifies a procedure.



The addition of this symbol to a Danger or Warning safety label indicates that an electrical hazard exists which will result in personal injury if the instructions are not followed.



This is the safety alert symbol. It is used to alert you to potential personal injury hazards. Obey all safety messages that follow this symbol to avoid possible injury or death.

### CAUTION

**CAUTION** indicates a potentially hazardous situation which, if not avoided, **can result in** minor or moderate injury.

### CAUTION

**CAUTION** addresses practices not related to physical injury including certain environmental hazards, potential damage or loss of data.

# Safety and General Information







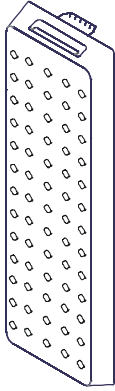

- Adhere to all national and local electrical codes.
- Changes and modifications to this unit not expressly approved by APC could void the warranty.
- This unit is intended only for indoor use in a controlled environment.
- Do not operate this unit in direct sunlight, in contact with fluids, or where there is excessive dust or humidity.
- Be sure the air vents on the unit are not blocked. Allow adequate space for proper ventilation.
- The battery typically lasts for three to five years. Environmental factors impact battery life. Elevated ambient temperatures, poor quality mains power, and frequent short duration discharges will shorten battery life.
- Before installing or replacing the batteries, remove jewelry such as wristwatches and rings. High, short circuit current through conductive materials could cause severe burns.
- The equipment is heavy. Always practice safe lifting techniques adequate for the weight of the equipment.
- The batteries are heavy. Remove the batteries before installing the UPS and external battery packs (XLBPs) in a rack.
- Always install XLBPs at the bottom in rack-mount configurations. The UPS must be installed above the XLBPs.
- The UPS will recognize as many as 10 XLBPs connected to the UPS. However there is no limit to the number of XLBPs that can be used with the UPS.  
**Note: For each XLBP added, increased recharge time will be required.**
- Do not dispose of batteries by burning them. The batteries may explode.
- Do not open or mutilate batteries. Released electrolyte is harmful to the skin and eyes, and may be toxic.
- Always recycle used batteries.
- Recycle the package materials or save them for reuse.
- Additional safety information can be found in the Safety Guide supplied with this unit.

## Overview

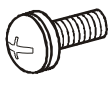
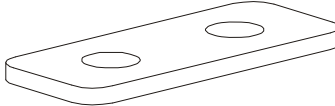
- To verify that installation of an external battery pack (XLBP) has been successful, go to the UPS display interface.  
Perform an **Alarm Test** to determine if the XLBP is recognized by the UPS.  
The LED on the XLBP will flash if successful communication has been established.
- When viewing the status of an XLBP on the UPS display interface screen, the LED on the corresponding XLBP will flash.
- When an RBC needs to be replaced, perform a **Runtime Calibration Test** to verify that battery replacement is required.

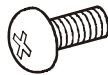
# Package Contents

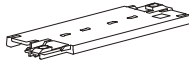
Inspect the contents upon receipt. Notify the carrier and dealer if there is damage.

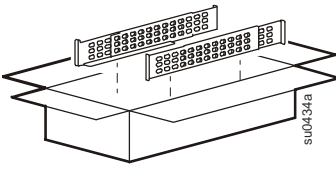
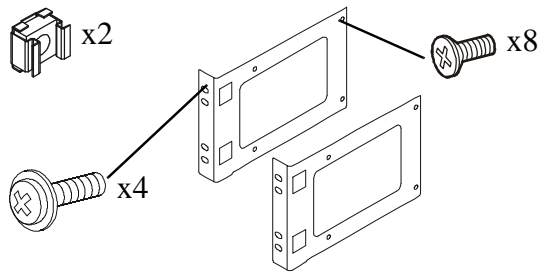
Included with all models			
<p>Front bezel</p> 	<p>Ground cable</p>  <p>2 pan head screws to secure the ground cable</p> 	<p>2 tie brackets</p>  <p>4 flat head screws to secure tie brackets</p> 	<p>User Documentation CD</p>  <p>1 pan head screw to secure the XLBP battery cable connector to an XLBP or to the UPS.</p> 
Included with SRT8K/SRT10K models only			
<p>Battery communication (BATT COMM) cable</p> 			
Included with SRT5K/SRT6K Tower models only			
<p>Stabilizer brackets are supplied with the SRT5K/SRT6K models The XLBP includes 1 stabilizer bracket connector</p> 		<p>4 flat head screws to secure tower stabilizer brackets to the UPS/</p> 	
Included with Rack-Mount models only			
<p>Rail Kit with instructions and hardware for installing rails in a rack</p> 		<ul style="list-style-type: none"> <li>• 1 pair rack-mount brackets</li> <li>• 8 flat head screws to secure rack-mount brackets to the UPS</li> <li>• 4 ornamental screws to secure rack-mount brackets to the rails</li> <li>• 2 cage nuts</li> </ul> 	

# Specifications

For additional specifications, refer to the APC web site at [www.apc.com](http://www.apc.com).

## Environmental

<b>Temperature</b>	<b>Operating</b>	0° to 40° C (32° to 104° F)
	<b>Storage</b>	-15° to 45° C (5° to 113° F)
<b>Maximum Elevation</b>	<b>Operating</b>	0 - 3,000 m (0 - 10,000 ft)
	<b>Storage</b>	0 - 15,000 m (50,000 ft)
<b>Humidity</b>	0% to 95% relative humidity, non-condensing	
<b>Protection Class</b>	IP 20 rating	
<p><b>Note:</b> Charge the battery modules every six months during storage.            Environmental factors impact battery life. Elevated ambient temperatures, high humidity, poor quality mains power, and frequent short duration discharges will shorten battery life.</p>		

## Physical

The XLBP is heavy. Follow all lifting guidelines.

<b>Lifting guidelines</b>	>55 kg (>120 lb) 
<b>Unit weight batteries included, without packaging</b>	91 kg (200.2 lb)
<b>Unit weight batteries included, with packaging</b>	101.5 kg (223.3 lb)
<b>Unit dimensions without packaging Height x Width x Depth</b>	130 mm x 432 mm x 682.7 mm 5.1 in x 17 in x 26.9 in
<b>Unit dimensions with packaging Height x Width x Depth</b>	420 mm x 600 mm x 1000 mm 16.5 in x 23.6 in x 39.4 in
The model and serial numbers are on a small label located on the rear panel.	

## Battery

<b>Battery type</b>	Maintenance free, leak proof, sealed, lead acid
<b>Replacement battery module</b> This UPS has hot swappable battery modules. Replacement is a safe procedure, isolated from electrical hazards.  Refer to the appropriate replacement battery user manual for installation instructions.  Contact your dealer or go the APC web site, <a href="http://www.apc.com">www.apc.com</a> for information on replacement batteries.	APCRBC140
<b>Number of battery modules</b>	4 battery modules
<b>Voltage for each battery module</b> <b>Total voltage for the UPS</b> <b>Ah rating</b>	96 VDC 192 VDC 5.1 Ah per battery module
<b>XLBP cable length</b>	500 mm (19.7 in)

# Remove Battery Modules

**⚠ CAUTION**

**DAMAGE TO EQUIPMENT OR PERSONNEL**

- Each battery module weighs 17 kg (37 lb).
- Always practice safe lifting techniques adequate for the weight of the equipment.
- Remove the battery modules before installing the XLBP.
- Use the battery module handle to carefully slide the battery modules in or out of the XLBP.
- Do not use the battery module handle to lift or carry the battery module.

**Failure to follow these instructions can result in equipment damage and minor or moderate injury.**

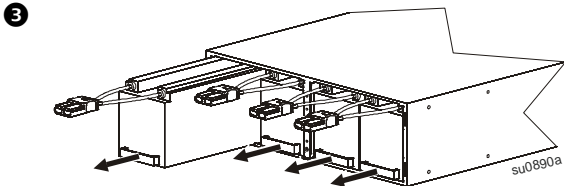
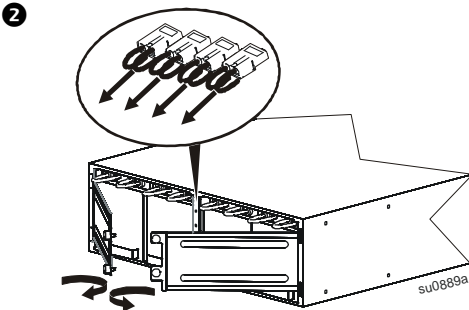
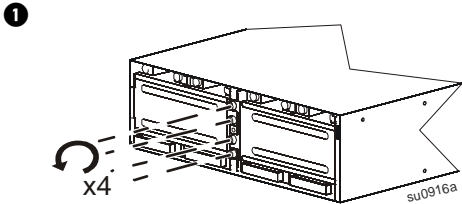

# Rack-Mount Installation

Your UPS model may differ in appearance from those depicted in these graphics.  
The XLBP installation process is identical for all models.

Refer to the rail kit Installation Guide for instructions on rail installation.

## CAUTION

### DAMAGE TO EQUIPMENT OR PERSONNEL

- The equipment is heavy. Always practice safe lifting techniques adequate for the weight of the equipment.
- Always use the recommended number of screws to secure brackets to the XLBP.
- Always use the recommended number of screws and cage nuts to secure the XLBP to the rack.
- Always install the XLBP at the bottom of the rack.
- Always install the XLBP below the UPS in the rack.
- Use the battery module handle to slide the battery modules in or out of the XLBP.
- Do not use the battery module handle to lift or carry the battery module.

**Failure to follow these instructions can result in equipment damage and minor or moderate injury.**

- ❶ Secure two brackets to the XLBP.  
Use four screws in each bracket.

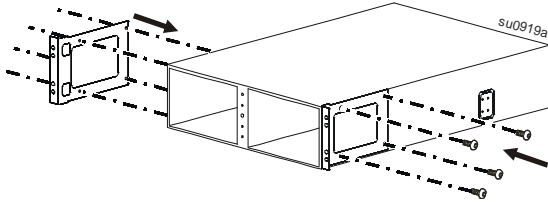

- ❷ Install two cage nuts.

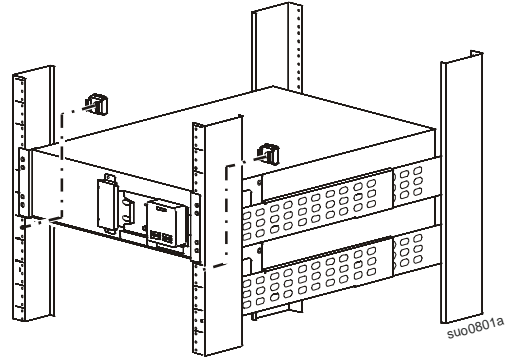

- ❸ Rest the XLBP on the rail shelves.  
Slide the XLBP into the rack.

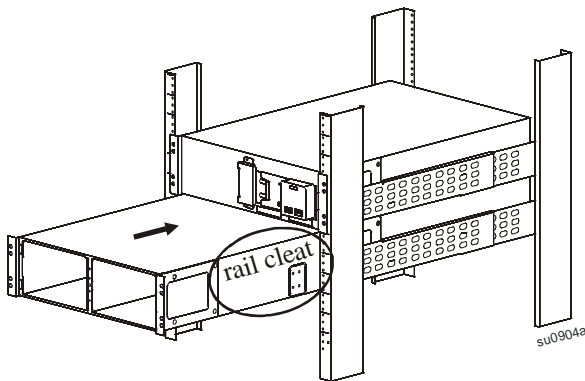

- ❹ Secure the XLBP to the rack.  
Use two screws in each bracket.

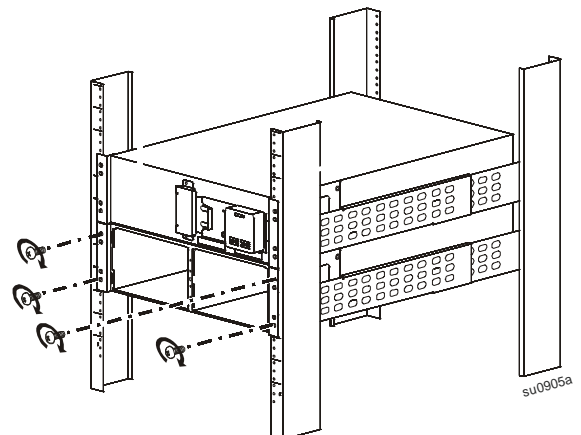

5 Install four battery modules.

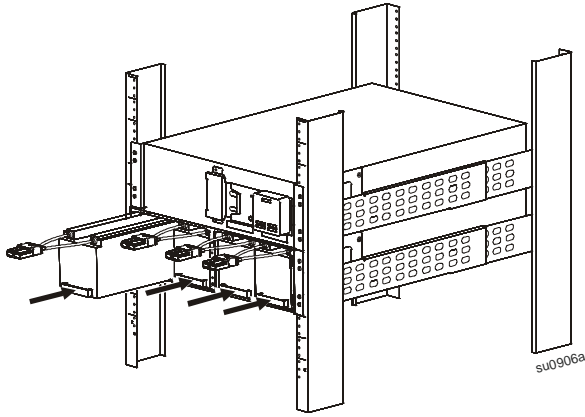

6 Connect four battery modules.

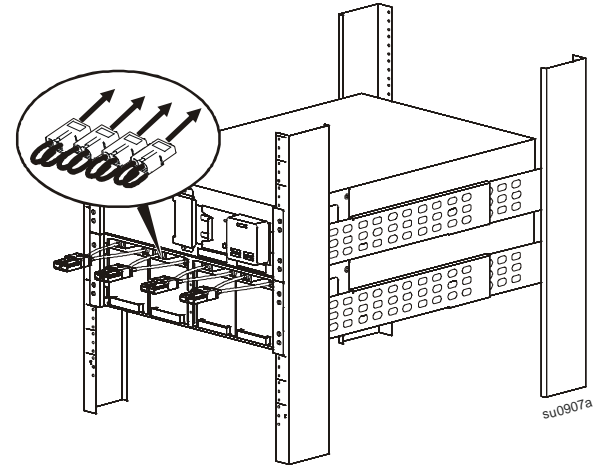

7 Reinstall the battery compartment doors.  
Tighten the thumbscrews to secure the doors.

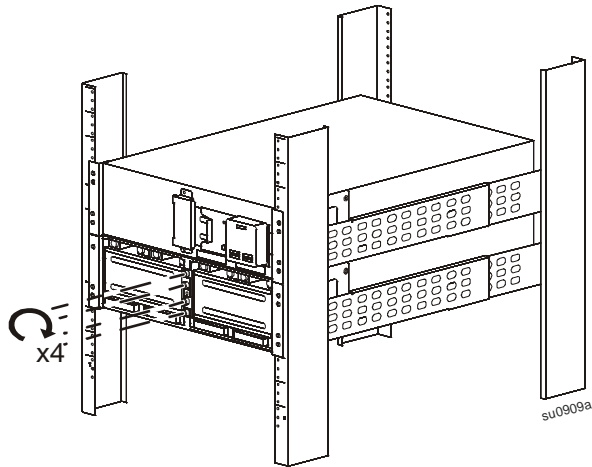

8 UPS models SRT5K or SRT6K with one XLBP  
Install one XLBP bezel and one UPS bezel.

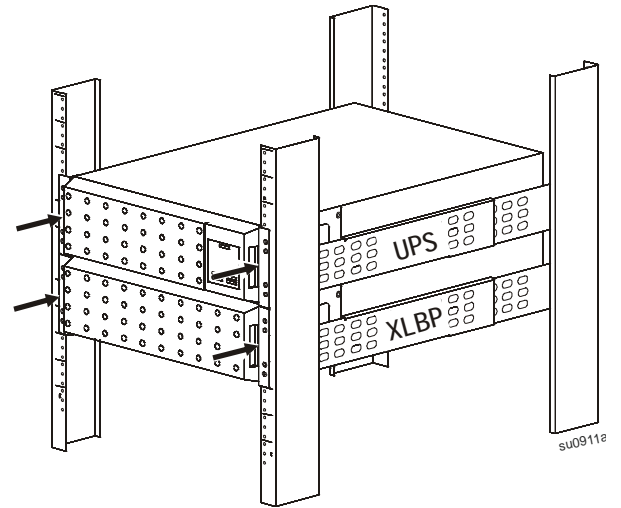

UPS models SRT8K or SRT10K with one XLBP  
Install one XLBP bezel and two UPS bezels.

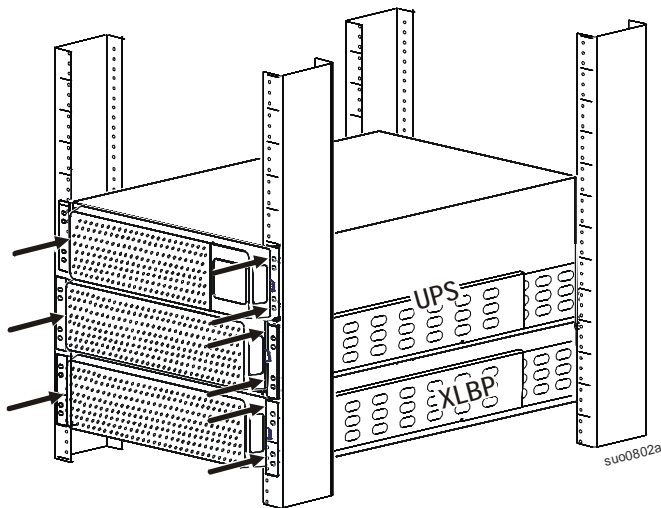

# Tower Installation

## ⚠ CAUTION

### DAMAGE TO EQUIPMENT OR PERSONNEL

- Prior to installing the tie brackets, select a location sturdy enough for the combined weight of the units.
- Do not move the units once the tie brackets are installed.
- Always install stabilizer brackets when an XLBP and UPS model SRT5K or SRT6K are installed together in tower configuration.
- Always install stabilizer brackets when an XLBP is installed in tower configuration and not secured to a UPS.

Failure to follow these instructions can result in equipment damage and minor or moderate injury.

### Stabilizer bracket installation UPS models SRT5K/SRT6K only

Stabilizer brackets are supplied with the SRT5K/SRT6K UPS models.

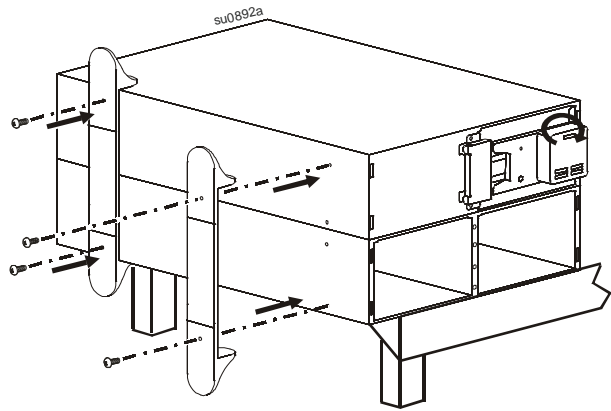
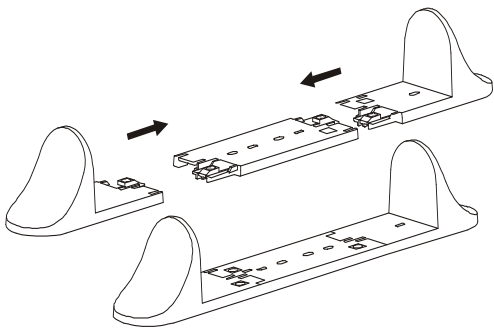

### Tie bracket installation all UPS models

❶ UPS models SRT5K/SRT6K with one XLBP

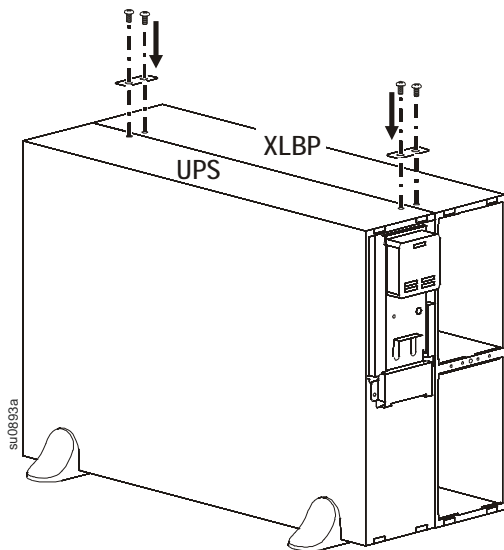

❷ UPS models SRT8K/SRT10K with one XLBP

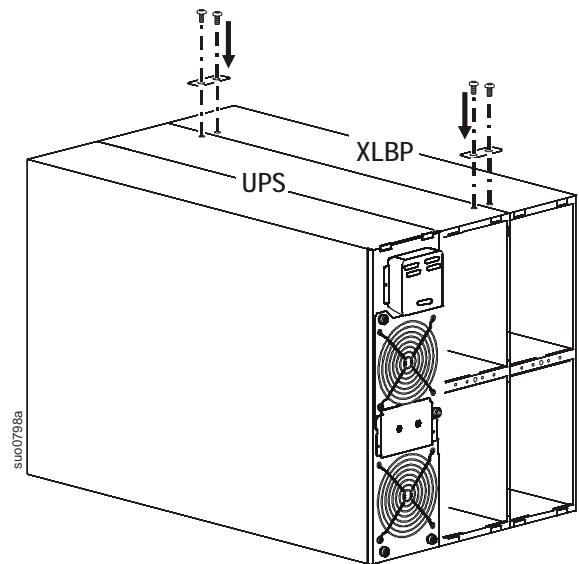



## Install battery modules and bezels SRT5K/SRT6K UPS models

- 1 Slide four battery modules into the XLBP. Connect four battery modules.

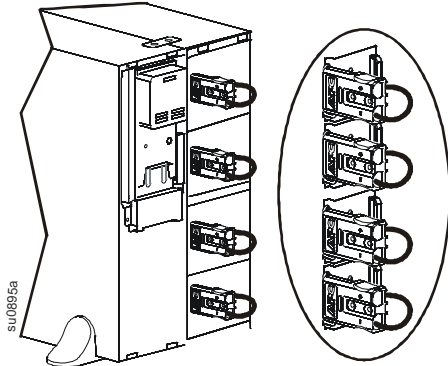

- 2 Reinstall the battery compartment doors. Tighten the thumbscrews to secure two doors.

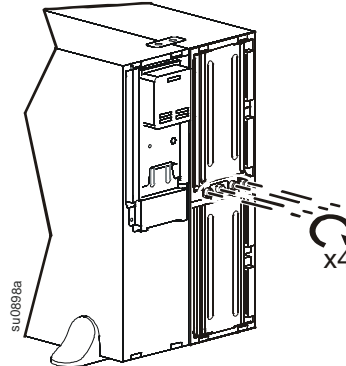

- 3 Install two bezels.

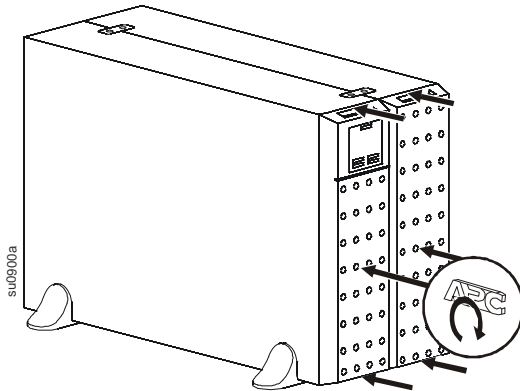

## SRT8K/SRT10K UPS models

- 1 Slide four battery modules into the UPS and four battery modules into the XLBP. Connect eight battery modules.

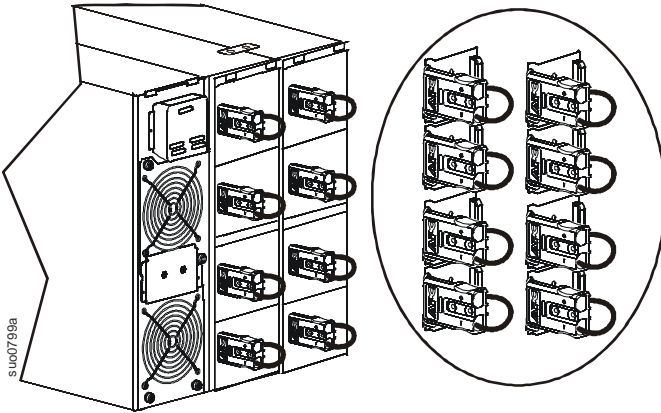

- 2 Reinstall the battery compartment doors. Tighten the thumbscrews to secure four doors.

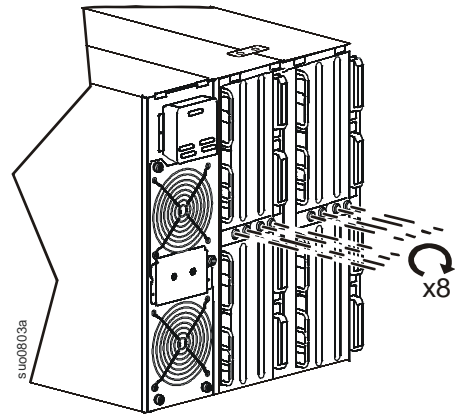

- 3 Install three bezels.

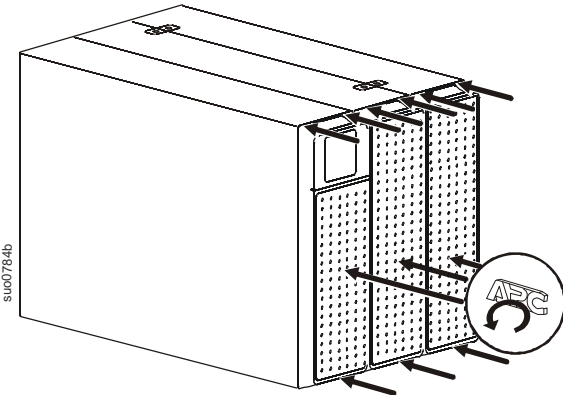

# Connect Ground and Battery Cables

SRT5K/SRT6K models

## Connect ground cables

Recommended screw torque, 2.72 Nm (24 lbf-in)

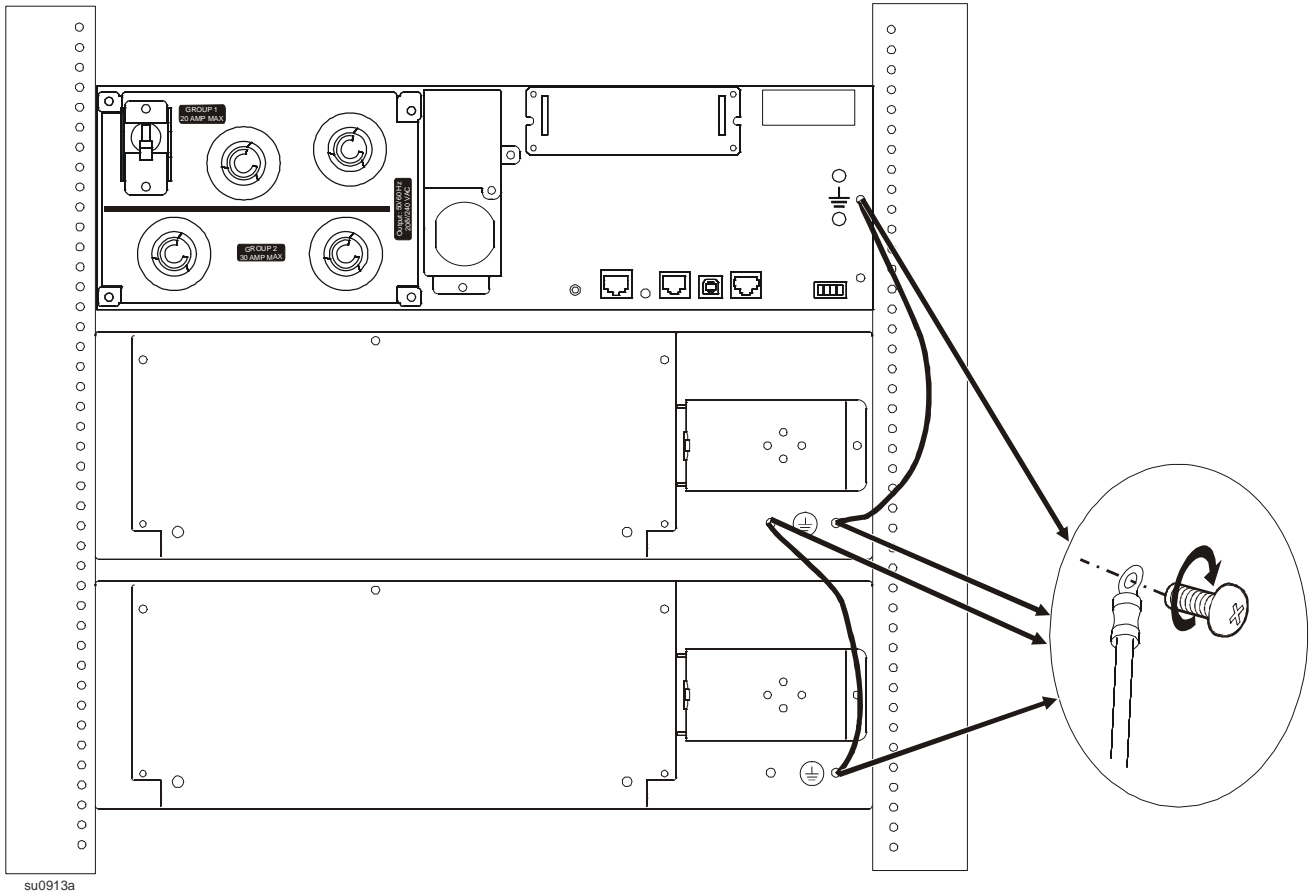

## Connect external battery pack cables

The UPS external battery pack connector has a cover, secured with a screw.

Remove the screw and the cover.  
Connect the external battery pack.

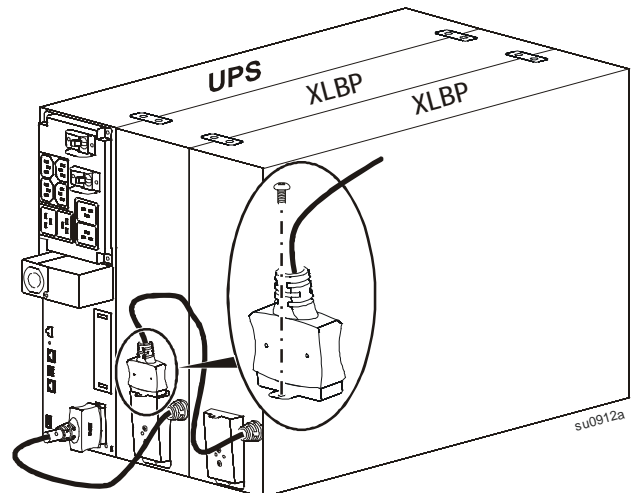

## SRT8K/SRT10K models

### Connect ground cables

Recommended screw torque, 2.72 Nm (24 lbf-in)

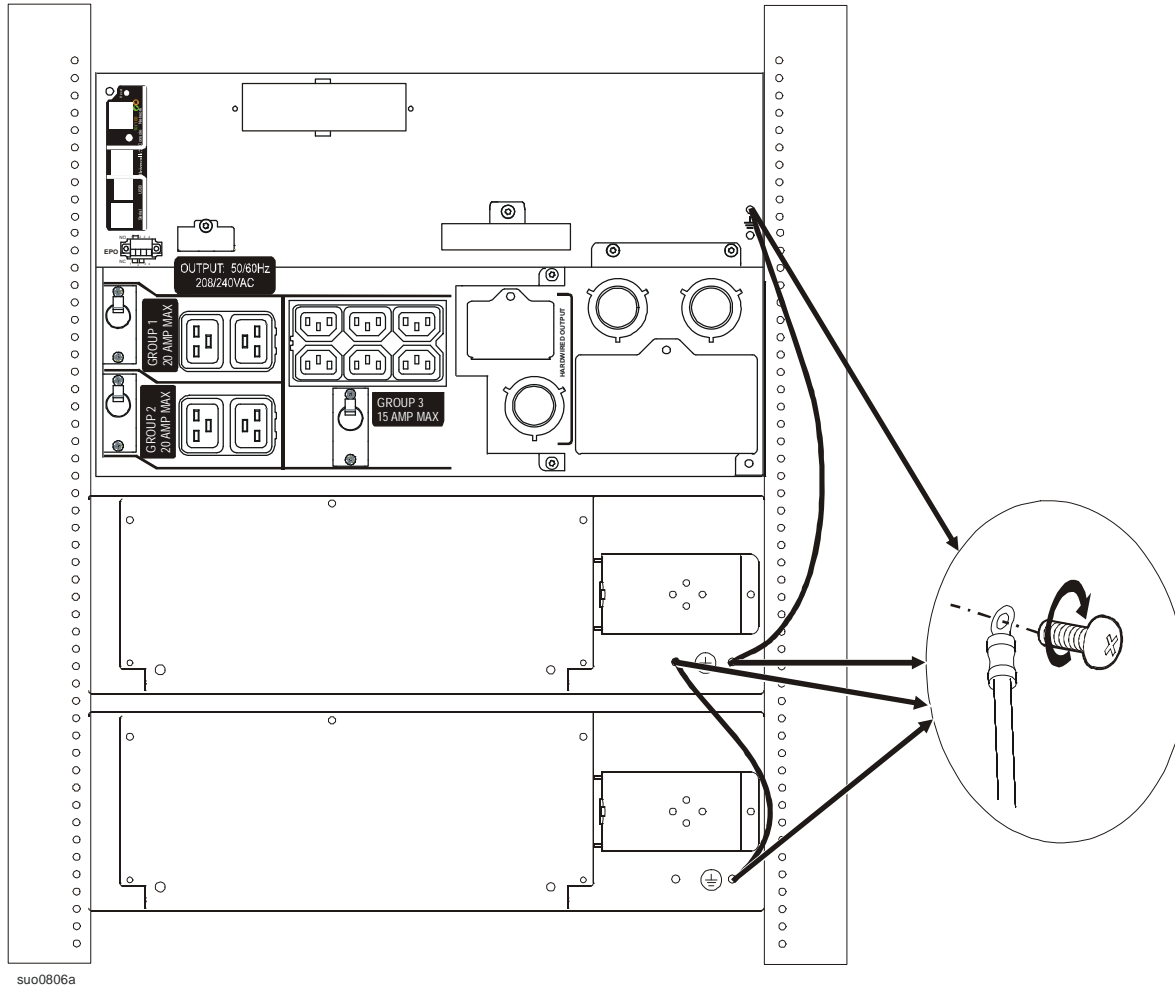

### Connect UPS battery pack, external battery packs and communication cables

The UPS external battery pack connector has a cover secured with a screw.

Remove the screw and the cover.

Connect the external battery pack.

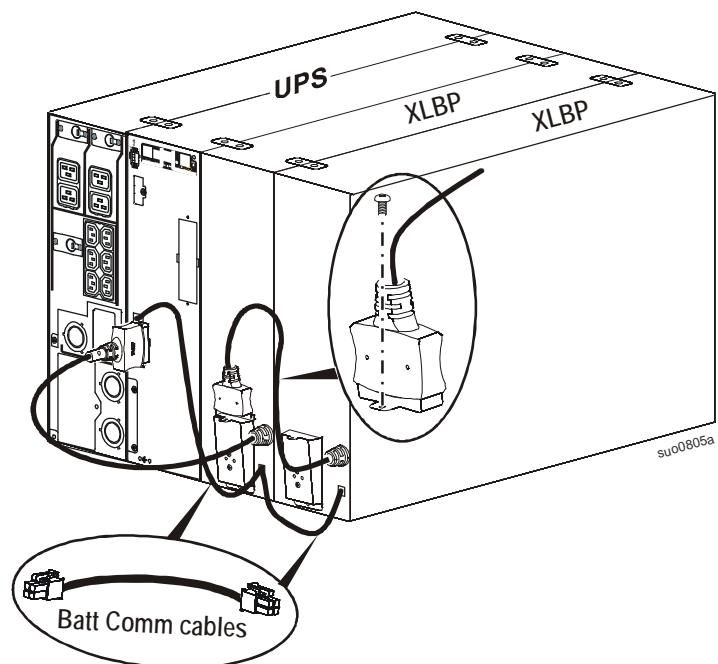

# Smart Battery Management

## Definitions

- **Battery Module:** A string of battery cells arranged to produce a battery assembly with a connector.
- **Replaceable Battery Cartridge (RBC):** An APC battery cartridge consisting of two battery modules. Replacement RBCs can be ordered from the APC web site, [www.apc.com](http://www.apc.com).
- **Smart External Battery Pack (XLBP):** An enclosure that contains RBC(s) and battery management electronics.
- **User Interface (UI):** Any interface by which a user can interact with the system. This may include a UPS display interface, a network management interface or PowerChute™ Network Shutdown software.

**NOTE: Do not use a battery that is not APC approved.**

**The system will not detect the presence of a non APC approved battery and may adversely affect the operation of the system.**

**Use of a non APC approved battery will void the manufacturer warranty.**

## Maintenance

- **RBC maintenance:** The APC RBC uses sealed lead acid battery cells and does not require maintenance.
- **Runtime Test (Calibration):** This should be performed anytime the steady state load is changed significantly, for example a new server is added to or removed from the UPS load.
- **Battery health monitoring:** The battery energy output and voltage are monitored to assess the health of the installed batteries when the UPS is operating on battery. Battery health monitoring is done during a UPS **Self Test**, a **Runtime Calibration Test**, and when the UPS is operating on battery power. The UPS can be configured to perform periodic, automatic **Self Tests**.

## End of useful life

- **Near end of life notification:** A warning message will appear on the UPS display interface screen when each RBC is approaching the end of its useful life. For configuration details refer to **Replacement Notification Time** and **Replacement Battery Alarm Time** in the UPS Operation Manual. The estimated replacement date for each RBC is available through the UI.
- **Needs replacement notification:** The UPS display interface screen shows when RBC replacement is required. The RBC must be replaced as soon as possible. When an RBC requires replacement, the UPS display interface may recommend that additional RBCs be replaced if they will soon reach the end of their useful life.

**CAUTION: Continued operation after end of useful life notification may cause damage to the batteries.**

- **Recycling:** Remove the RBC from the XLBP. Recycle the RBC. Do not disassemble an RBC.

## Recommended actions after installing new RBCs or XLBPs

Refer to the UPS Operation Manual for details on **Test and Diagnostics Menu** options for the following tests:

- Self Test
- Runtime Test
- Alarm Test

The following actions should be performed after installing a new RBC or XLBP:

- Verify that the UPS is connected to input power and output power is turned on. Refer to the *Operation* section in this manual for instructions.
- When a new XLBP is installed, verify that the XLBP is detected by the system.
  - Perform a **UPS Alarm Test**.
  - Check that the LED on all installed XLBPs continuously flashes.
- To verify that installation of a replacement battery cartridge (RBC), has been successful, go to the UPS display interface. Use the Status menus to verify that the UPS recognizes the RBCs.
- Verify that the UPS load is greater than 400 watts. This will appear on the UPS display interface.
- Perform a **UPS Self Test**.
- If at the time of XLBP installation UPS input power is not available, turn on the UPS output from battery power for 30 seconds. This will allow the UPS to detect all installed RBCs.  
Refer to the UPS Operation Manual for instructions on how to turn the UPS on and off.
- Verify on the UPS display interface that the installation dates for the replaced RBCs are set to the current date. The installation dates can be changed manually on the UPS display interface.  
If all RBCs have been replaced at the same time, all installation dates can be changed simultaneously.  
For configuration details refer to **Battery Install Date** in the Operation Manual.
- Allow the system to charge for 24 hours to ensure full runtime capability.
- Initiate a **Runtime Calibration Test** through the UI.

## User interface

**View Status/Error notifications:** The status of connected XLBPs can be viewed using the UPS display interface menu options.

- **XLBP Status LED:** The XLBP LED illuminates red to indicate three possible states.
  - **Off:** No message. This is the default state.
  - **Solid red:** XLBP cannot communicate with the UPS. The XLBP controller is not functional.
  - **Flashing red:**
    - For identification purposes each XLBP is automatically assigned a number. To verify the number of a specific XLBP, use the UPS display interface menu options. Select an XLBP number. The LED will flash on the XLBP assigned to that number.
- **XLBP LED test:** From the UPS display interface, LED functionality can be tested by issuing an **Alarm Test**. This command causes the LED on each connected XLBP to flash.
- **System interfaces:** Battery status, alerts, and measurements are shown on the UPS display interface screen. Refer to the UPS Operation Manual.

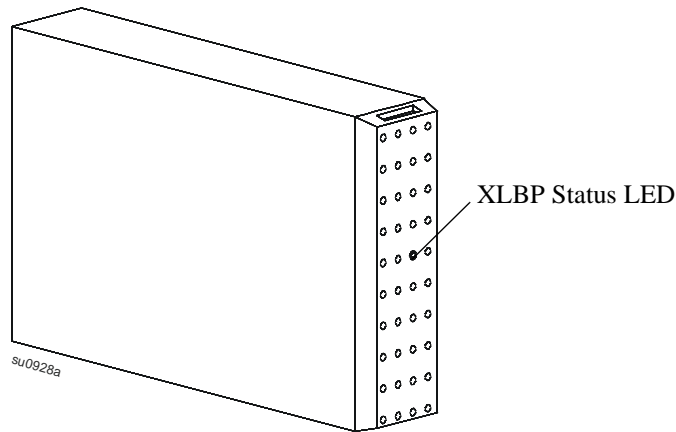

# Troubleshooting

Issues	Possible Cause	Solution
XLBP LED flashes.	<ul style="list-style-type: none"> <li>• The UPS display interface is requesting XLBP status</li> <li>• <b>Alarm Test</b> has been requested by the UPS</li> <li>• Indicates that an RBC needs to be replaced</li> </ul>	<ul style="list-style-type: none"> <li>• No action is necessary.</li> <li>• No action is necessary.</li> <li>• Refer to the UPS display interface screen for information.</li> </ul>
XLBP LED remains illuminated	Potential hardware error exists	<ul style="list-style-type: none"> <li>• Contact APC Customer Support. Refer to the <b>Service</b> section in the Operation Manual for contact information.</li> </ul>
UPS display interface shows an RBC disconnected message.	<ul style="list-style-type: none"> <li>• RBC is not connected</li> <li>• RBC hardware error exists</li> </ul>	<p>Connect the RBCs. Verify that the UPS recognizes the RBCs.</p> <p>Perform a UPS <b>Self Test</b>.</p> <p>If the message remains on the display interface screen replace the RBC.</p>
XLBP is not recognized.	<ul style="list-style-type: none"> <li>• Communication issue exists</li> <li>• Potential hardware error exists</li> </ul>	<ul style="list-style-type: none"> <li>• Be sure the battery connections to the XLBPs are secure.</li> <li>• Be sure the connection between the XLBPs and the UPS are secure.</li> <li>• Perform an <b>Alarm Test</b> to verify that the LED flashes.</li> <li>• If issue persists, contact APC Customer Support. Refer to the <b>Service</b> section in the Operation Manual for contact information.</li> </ul>
UPS display interface shows XLBP disconnected message.	<ul style="list-style-type: none"> <li>• Power cable is not securely connected to an XLBP or to the UPS</li> <li>• XLBP hardware error</li> </ul>	<ul style="list-style-type: none"> <li>• Be sure the battery connections to the XLBPs are secure.</li> <li>• Perform an <b>Alarm Test</b> to verify that the LED flashes.</li> <li>• If issue persists, contact APC Customer Support. Refer to the <b>Service</b> section in the Operation Manual for contact information.</li> </ul>



# Limited Factory Warranty

Schneider Electric IT Corporation (SEIT), warrants its products to be free from defects in materials and workmanship for a period of two (2) years excluding the batteries, which are warranted for two (2) years from the date of purchase. The SEIT obligation under this warranty is limited to repairing or replacing, at its own sole option, any such defective products. Repair or replacement of a defective product or parts thereof does not extend the original warranty period.

This warranty applies only to the original purchaser who must have properly registered the product within 10 days of purchase. Products may be registered online at [warranty.apc.com](http://warranty.apc.com).

SEIT shall not be liable under the warranty if its testing and examination disclose that the alleged defect in the product does not exist or was caused by end user or any third person misuse, negligence, improper installation, testing, operation or use of the product contrary to SEIT recommendations or specifications. Further, SEIT shall not be liable for defects resulting from: 1) unauthorized attempts to repair or modify the product, 2) incorrect or inadequate electrical voltage or connection, 3) inappropriate on site operation conditions, 4) Acts of God, 5) exposure to the elements, or 6) theft. In no event shall SEIT have any liability under this warranty for any product where the serial number has been altered, defaced, or removed.

**EXCEPT AS SET FORTH ABOVE, THERE ARE NO WARRANTIES, EXPRESS OR IMPLIED, BY OPERATION OF LAW OR OTHERWISE, APPLICABLE TO PRODUCTS SOLD, SERVICED OR FURNISHED UNDER THIS AGREEMENT OR IN CONNECTION HERewith.**

**SEIT DISCLAIMS ALL IMPLIED WARRANTIES OF MERCHANTABILITY, SATISFACTION AND FITNESS FOR A PARTICULAR PURPOSE.**

**SEIT EXPRESS WARRANTIES WILL NOT BE ENLARGED, DIMINISHED, OR AFFECTED BY AND NO OBLIGATION OR LIABILITY WILL ARISE OUT OF, SEIT RENDERING OF TECHNICAL OR OTHER ADVICE OR SERVICE IN CONNECTION WITH THE PRODUCTS.**

**THE FOREGOING WARRANTIES AND REMEDIES ARE EXCLUSIVE AND IN LIEU OF ALL OTHER WARRANTIES AND REMEDIES. THE WARRANTIES SET FORTH ABOVE CONSTITUTE SEIT'S SOLE LIABILITY AND PURCHASER EXCLUSIVE REMEDY FOR ANY BREACH OF SUCH WARRANTIES. SEIT WARRANTIES EXTEND ONLY TO ORIGINAL PURCHASER AND ARE NOT EXTENDED TO ANY THIRD PARTIES.**

**IN NO EVENT SHALL SEIT, ITS OFFICERS, DIRECTORS, AFFILIATES OR EMPLOYEES BE LIABLE FOR ANY FORM OF INDIRECT, SPECIAL, CONSEQUENTIAL OR PUNITIVE DAMAGES, ARISING OUT OF THE USE, SERVICE OR INSTALLATION OF THE PRODUCTS, WHETHER SUCH DAMAGES ARISE IN CONTRACT OR TORT, IRRESPECTIVE OF FAULT, NEGLIGENCE OR STRICT LIABILITY OR WHETHER SEIT HAS BEEN ADVISED IN ADVANCE OF THE POSSIBILITY OF SUCH DAMAGES. SPECIFICALLY, SEIT IS NOT LIABLE FOR ANY COSTS, SUCH AS LOST PROFITS OR REVENUE, WHETHER DIRECT OR INDIRECT, LOSS OF EQUIPMENT, LOSS OF USE OF EQUIPMENT, LOSS OF SOFTWARE, LOSS OF DATA, COSTS OF SUBSTITUANTS, CLAIMS BY THIRD PARTIES, OR OTHERWISE.**

**NOTHING IN THIS LIMITED WARRANTY SHALL SEEK TO EXCLUDE OR LIMIT SEIT LIABILITY FOR DEATH OR PERSONAL INJURY RESULTING FROM ITS NEGLIGENCE OR ITS FRAUDULENT MISREPRESENTATION OF TO THE EXTENT THAT IT CANNOT BE EXCLUDED OR LIMITED BY APPLICABLE LAW.**

To obtain service under warranty you must obtain a Returned Material Authorization (RMA) number from customer support. Customers with warranty claims issues may access the SEIT worldwide customer support network through the APC web site: [www.apc.com](http://www.apc.com). Select your country from the country selection drop down menu. Open the Support tab at the top of the web page to obtain information for customer support in your region. Products must be returned with transportation charges prepaid and must be accompanied by a brief description of the problem encountered and proof of date and place of purchase.

# APC by Schneider Electric Worldwide Customer Support

Customer support for this or any other APC by Schneider Electric product is available at no charge in any of the following ways:

- Visit the APC web site to access documents in the APC Knowledge Base and to submit customer support requests.
  - **www.apc.com** (Corporate Headquarters)  
Connect to localized APC web sites for specific countries, each of which provides customer support information.
  - **www.apc.com/support/**  
Global support searching APC Knowledge Base and using e-support.
- Contact APC Customer Support Center by telephone or e-mail.
  - Local, country specific centers: go to **www.apc.com/support/contact** for contact information.
  - For information on how to obtain local customer support, contact the APC by Schneider Electric representative or other distributor from whom you purchased your APC by Schneider Electric product.

Customer support and warranty information are available on the APC web site, **www.apc.com**.

© 2014 APC by Schneider Electric. APC, the APC logo, and Smart-UPS are owned by Schneider Electric Industries S.A.S., or their affiliated companies. All other trademarks are property of their respective owners.

**EN 990-4811B**  
**06/2014**